

# Quick Installation Guide \_ for Parallel System



## Part 1 Preparation

### 1.1 System Diagram

Only cables marked with majuscule in below system diagram will be introduced in this manual.  
For other cables connection, here will not be described.

- A** EPS connection between Inverter and parallel box (refer to Part 2)
- B** Grid connection between Grid Distribution Box and parallel box (refer to Part 2)
- C** EPS Load connection between EPS load and parallel box (refer to Part 2)
- D** Earth connection between parallel box and external earth bar (refer to Part 2)
- E** Earth connection between parallel box and EPS Load (refer to Part 2)
- F** Communication connection between parallel box and Master Inverter (refer to Part 2)
- G** Communication connection between Inverters (refer to Part 3)
- H** Communication connection between Master Inverter and SOLAX meter (refer to Part 3)

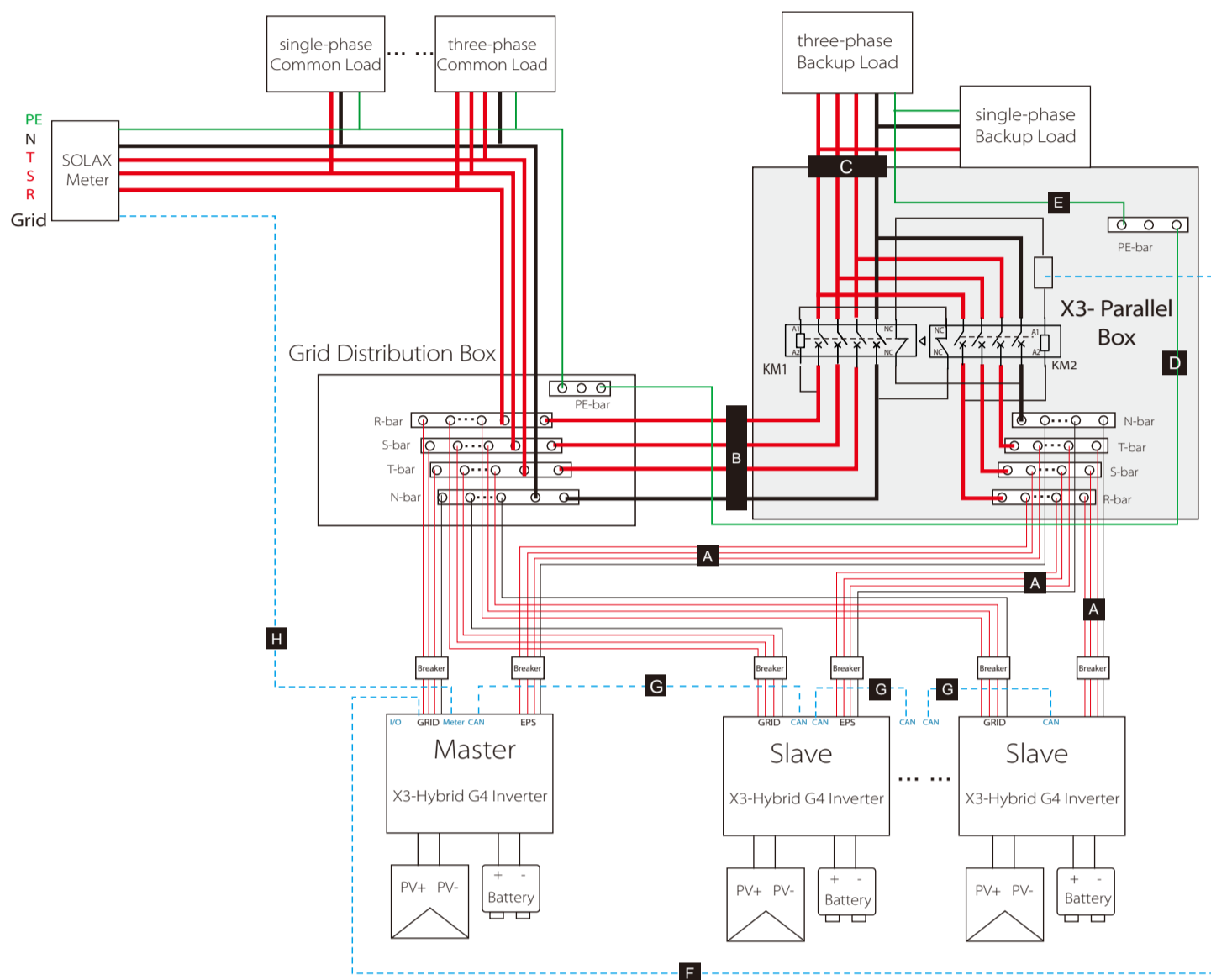

### 1.2 Packing List

Expansion bolt * 4, Gasket * 4	Cold-pressed terminal (22-6) * 3, (22-8) * 5	Cold-pressed terminal(S-5) * 28	RJ 45 terminals * 1 Communication terminal (green) * 1 (choose a suitable one when installing)	Board marking paper * 1	4AWG European terminals (25-18) * 5
M4 inner hexagon bolt * 1	Ground terminal (length, 250mm) * 1	Natural line(Black) * 1 (For Australia)	Ground terminal (length, 30mm) * 1 (For other areas)	Warranty card * 1	Quick Installation Guide * 1

### 1.3 Cable Preparation

- Press the terminal harness.

Connectors	Application	Connectors	Application	Connectors	Application	Connectors	Application
R/S/T/N EPS Connector X 6 pairs		R/S/T/N Grid Connector X 2 pairs		RJ 45 terminals 1 pcs		Switching communication connection X1 pcs	

### 1.4 Mounting

- Use the attachment bag of control cardboard drill four  $\Phi 8$  holes.
- Depth: at least 80mm
- Tighten the expansion tubes.
- Pass the expansion screws through the M6 washers, then screw the expansion screws. (Torque: 8.0 N·m)

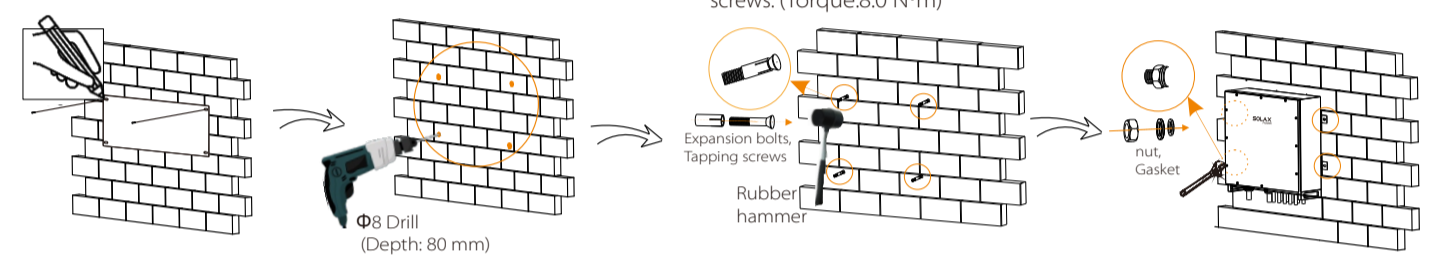

Notes: Affix the empty cabinet on the wall first before proceeding any installation. It will be too dangerous to move as the box fitting with switch will over weigh cabinet handle's bearing limit.

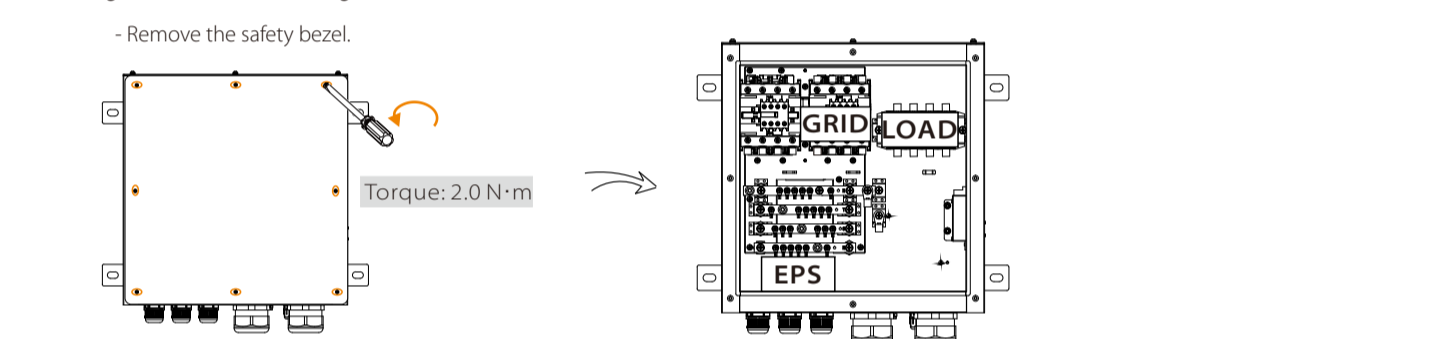

## Part 2 Installation of Parallel BOX

### 2.1 Connection Overview of Parallel BOX

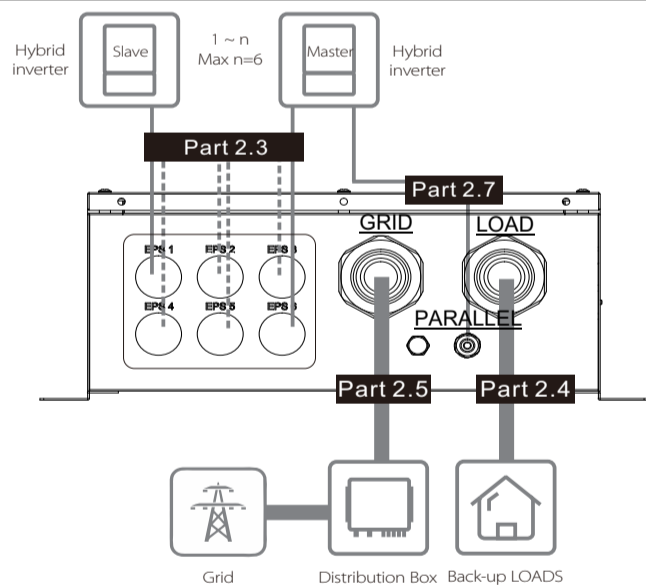

**Important Warning!**  
Every cable must be connected according to correct line sequence(R-R, S-S, T-T, N-N), otherwise any small misoperation may cause the system running failed.

- 2.3** EPS Connection
- 2.4** Back-up Load Connection
- 2.5** GRID Connection
- 2.7** Communication Connection

### 2.2 Cable Size Recommended

Category	Cable Type	Specification
EPS	R-cable, S-cable, T-cable, N-cable	6mm <sup>2</sup> * 4 PCS for one EPS port
	Outer Diameter of EPS Cable	12.5-18 mm
	4 cables needed for one EPS port (one inverter) 8 cables needed for two EPS ports (two inverters paralleled) 24 cables needed for ten EPS ports maximum (Six inverters paralleled)	
Back-up Load	R-cable, S-cable, T-cable, N-cable	25mm <sup>2</sup> * 4 PCS
	Outer Diameter of LOAD Cable	18-44 mm.
Grid	R-cable, S-cable, T-cable, N-cable	25mm <sup>2</sup> * 4 PCS
	PE-cable	10mm <sup>2</sup> * 1 PCS
	Outer Diameter of GRID Cable	18-44mm
Communication	Communication cable	≥0.2mm <sup>2</sup> * 2 PCS for one communication port
	Outer Diameter of Communication Cable	6-8 mm

### 2.3 EPS Connection

#### Connection of EPS Parallel Box side

- Make EPS cables**  
Remove 10mm insulation from cable ends, then Insert the stripping terminal. Press the terminal head with the blank holder.

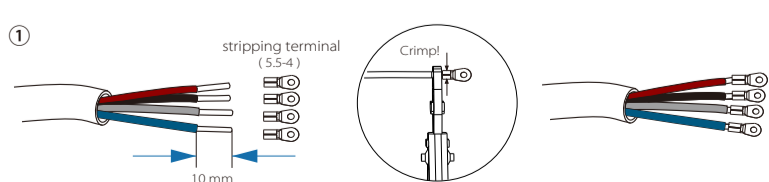

- Screw cables**  
Screw cables through the EPS port on the bottom of the BOX to corresponding EPS ports (R-bar, S-bar, T-bar, N-bar, G-bar) by screwdriver. (refer to picture as right)

Torque: 1.0 N·m

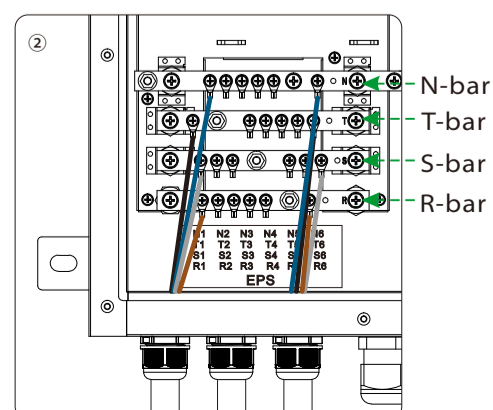

#### Connection of Inverter side (please refer to Inverter User Manual for details)

- Make other side of EPS cables**  
Remove 10mm insulation from cable ends, then Insert the AC terminal. Press the terminal head with the blank holder.

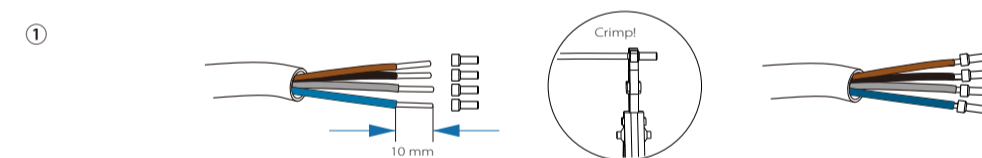

#### Screw cables

- Insert cables into EPS port through screw cap. Insert R(L1),S(L2),T(L3),N cables into corresponding ports of EPS terminal and screw them tightly. (For specific installation steps, please refer to the EPS port installation chapter of the X3-Hybrid/Fit Quick Installation Guide.)

#### Apply to X3-Hybrid G4:

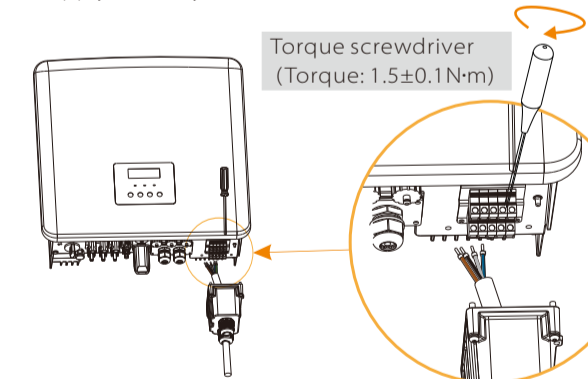

Torque screwdriver (Torque: 1.5±0.1 N·m)

#### X3-Hybrid/Fit G2:

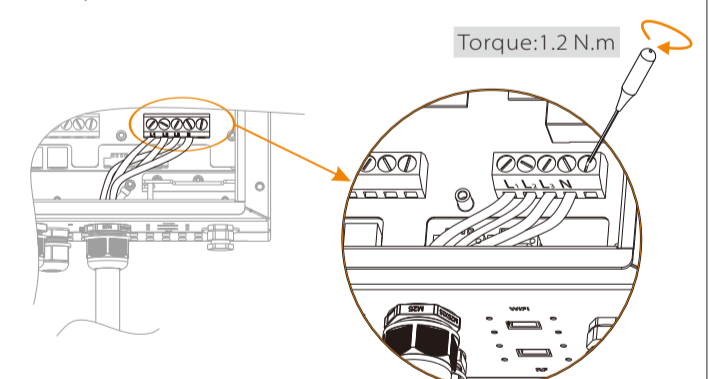

Torque: 1.2 N·m

### 2.4 Back-up Load Connection

#### Connection of Parallel Box side

- Make Load cables**  
Remove 12mm insulation from cable ends, then Insert the stripping terminal. Press the terminal head with the blank holder.

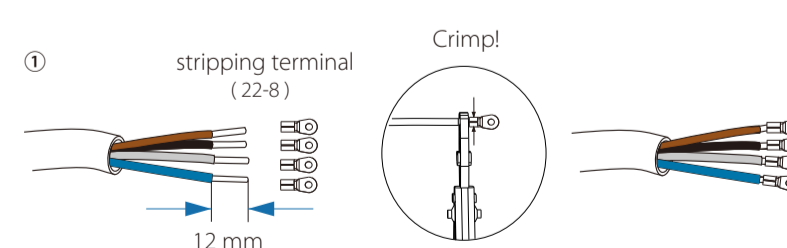

#### Screw cables

- Pass the completed wiring harness through the Load port and follow the corresponding wiring ports (R-bar, S-bar), T-bar, N-bar) install it and tighten the screws. (Torque: 4.0 N·m) (refer to picture as right)

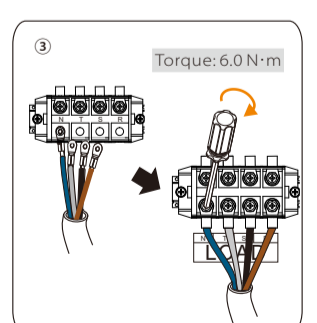
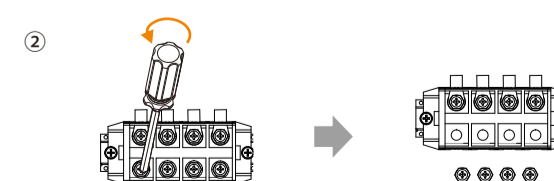

Torque: 6.0 N·m

#### Connection of back-up load side

- Selecting appropriate Back-up loads**

The requirement shown as below must be satisfied:

- 1: Algebraic apparent power of back-up loads **must be less than** Algebraic apparent power of hybrid system \* 0.9
- 2: Algebraic RCD apparent power of RCD back-up loads **must be less than** Algebraic apparent power of hybrid system \* 0.6.

Back-up Load connection of loads side should be analyzed and operated depending on specific loads. Here will not be described into details.

# Part 2 Installation of Parallel BOX

## 2.5 GRID Connection

### Connection of Parallel Box side

#### Make Grid cables

Remove 18mm insulation from cable ends, then Insert the stripping terminal. Press the terminal head with the blank holder.

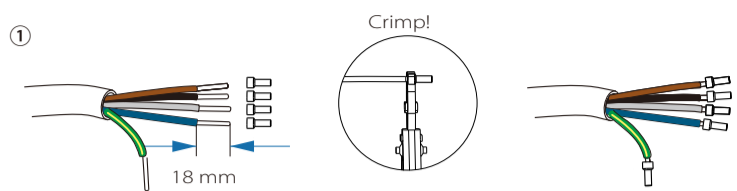

#### Screw cables

Screw cables through the GRID port on the bottom of the BOX to corresponding Load ports (R-bar, S-bar, T-bar, N-bar, G-bar) by screwdriver.

Note: For users in most countries, you need to find a ground cable from the accessories, and short-circuit the N-bar of EPS with PE; for **Australian** users, you can find a **Natural line(Black)** in the accessories to connect the N terminal of the Grid Connect with the N-bar of EPS. (refer to picture as below) Torque:4.0 N·m

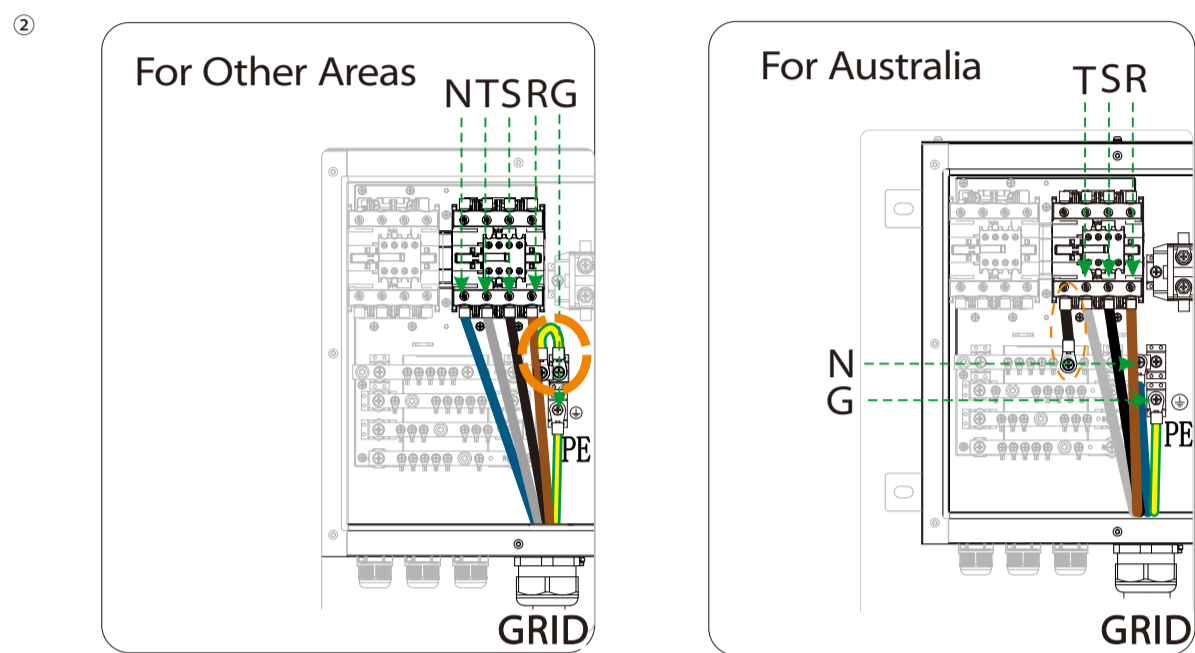

### Connection of Grid distribution box side

Grid port connection of grid distribution box side should be analyzed and operated depending on field wiring condition. Here will not be described into details.

## 2.6 Ground Connection

Step 1: Find a longer ground cable from the attachment.



Step 2: Twist the screw between the ground terminal inside the cabinet and the ground terminal of the chassis, connect them with a ground cable, and tighten the screws.

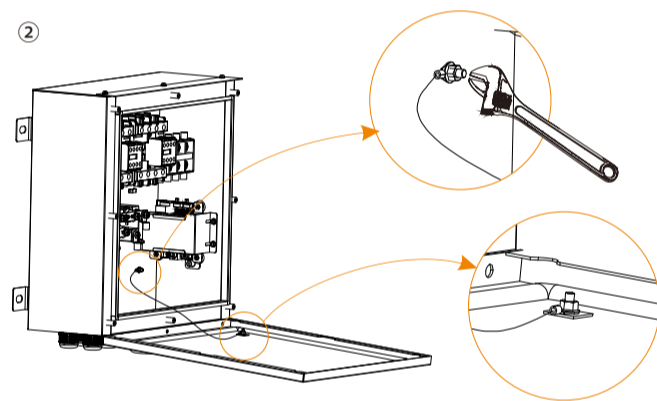

- Finally, install the upper cover of the machine and tighten the screws.

## 2.7 Communication Connection

### Connection of Parallel Box side

#### Make communication cables

If the user is used with X3-Hybrid/Fit G2 inverter, please connect as follows: Remove 4mm insulation from cable ends.

Insert the cable into the green terminal in the accessory bag, then use a screwdriver to tighten the cable and insert it into the corresponding port. Torque:0.2±0.1 N·m

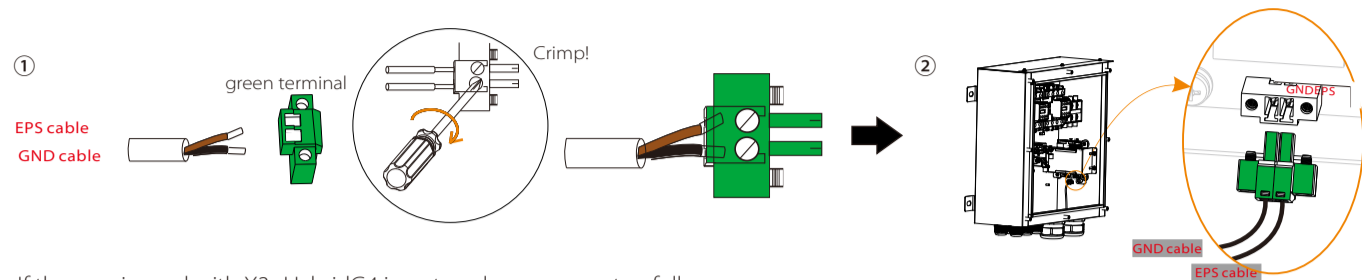

If the user is used with X3-HybridG4 inverter, please connect as follows: Use a common network cable and Remove 4mm insulation from cable ends.

Insert the cable into the RJ45 terminal in the accessory kit, then use a diagonal pliers to tighten the cable and insert it into the corresponding port.

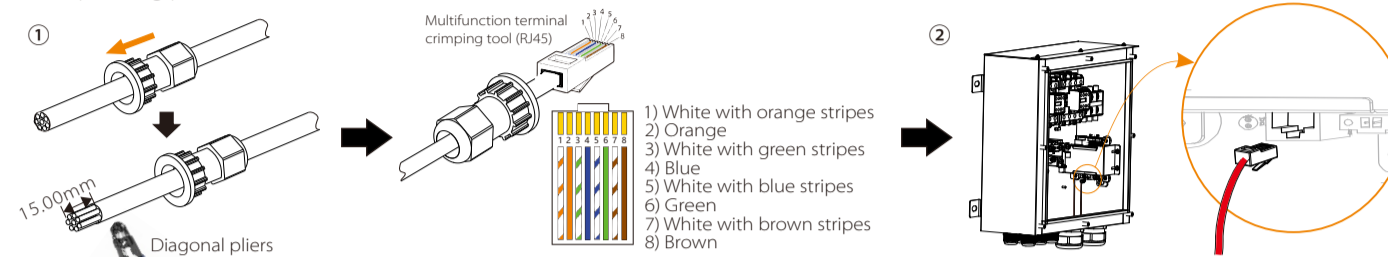

### Connection of Inverter side (please refer to Inverter User Manual for details)

If the user is used with X3-Hybrid/Fit G2 inverter, please connect as follows:

#### Prepare a connector and two communication cables.

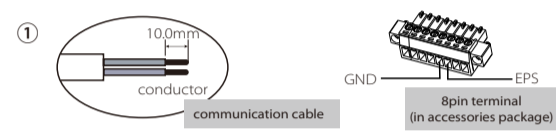

#### Insert the cables

Unscrew the nut of connector on the bottom of the inverter and insert two communication cables through it.

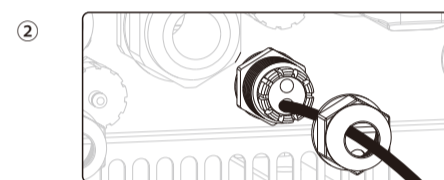

#### Screw the wires

Disconnect the insulation layer of the communication cable, and then insert one side of the cable corresponding to the GND and EPS port into the pin5 and pin6 holes of the 8-pin positive terminal in the accessory bag.

Torque: 0.2±0.1 N·m

#### Screw the terminal

Insert the positive terminal into the corresponding negative terminal block inside of the inverter. And then screw it tightly.

Torque:0.4±0.1 N·m

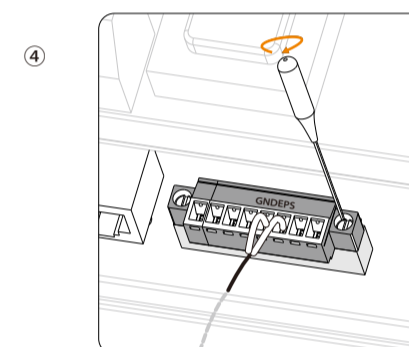
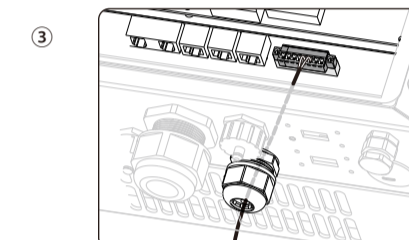

If the user is used with X3-Hybrid G4 inverter, please connect as follows:

\* Note: It is best to connect the CAN port on the left of "Master" to X3-Parallel Box, and connect the CAN port on the right to "Slave".

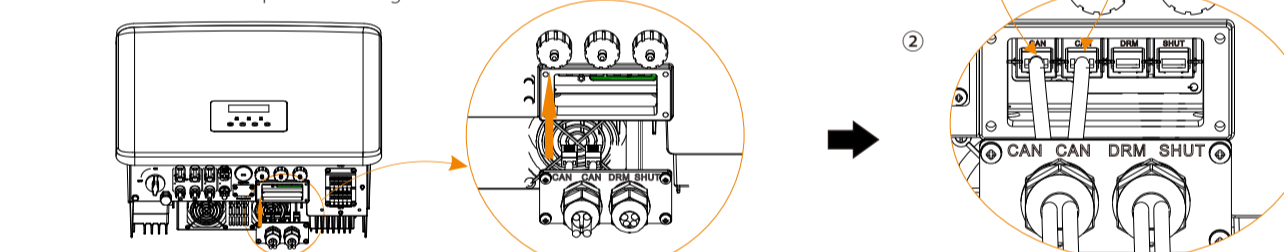

# Part 3 Installation of Parallel System

#### CAN-CAN connection:

Insert one side of CAT7 cable into the first inverter's CAN port and the other side into the next inverter's CAN port.

#### RS485-Meter connection:

Insert one side of CAT5 cable into the RS485 port of meter, and the other side into the CAN 1 port of the first inverter or the CAN 2 port of the last inverter.

Please note the inverter connected with meter will be the Master Inverter and this Master inverter must be connected with battery.

If the user is used with X3-Hybrid G4 inverter, please connect as follows:

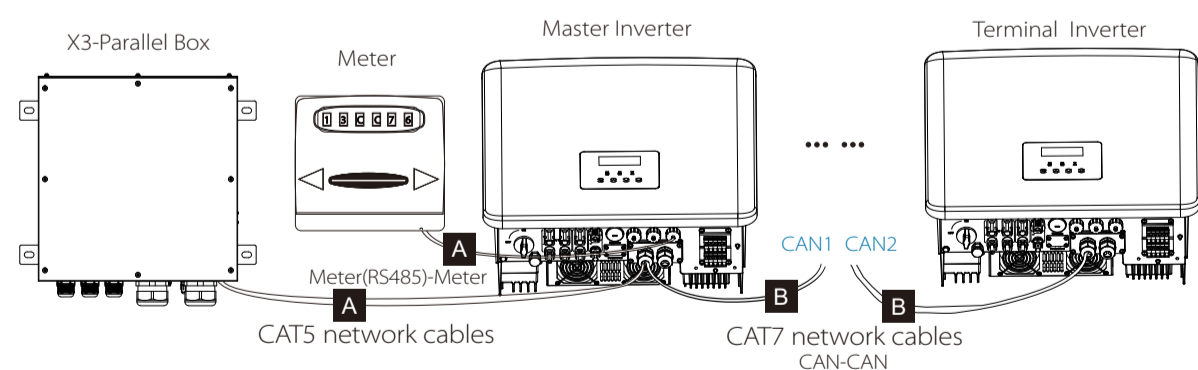

If the user is used with X3-Hybrid/Fit G2 inverter, please connect as follows:

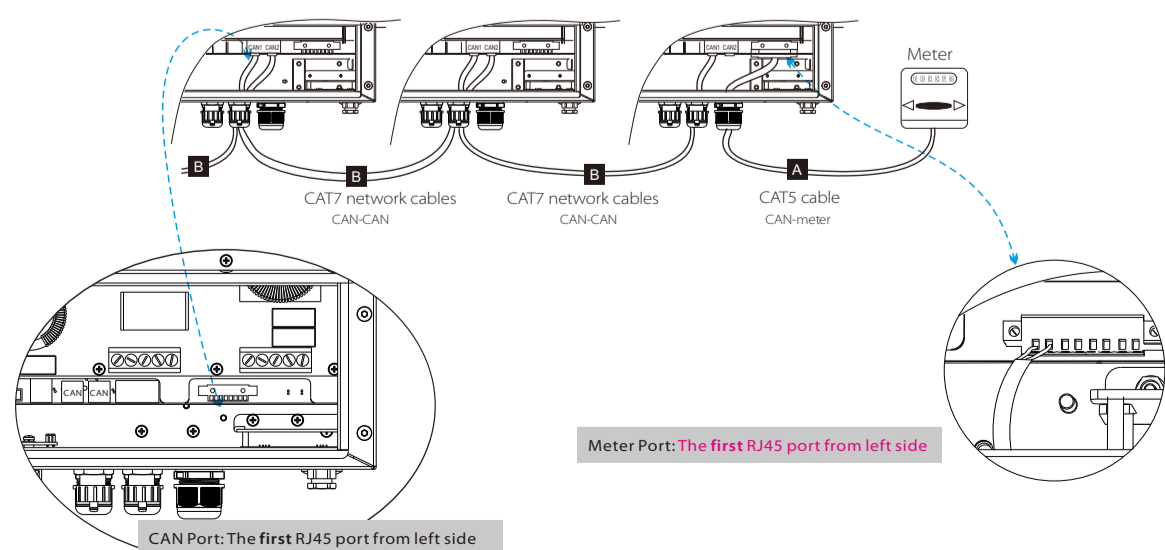

Note: For specific cable operation of these cables, please refer to Inverter User Manual.

# Part 4 LCD Operation

There are three work modes in parallel system, and your acknowledge of different inverter's work modes will help you understand parallel system better, therefore please read it carefully before operating.

Free mode	Only if no one inverter is set as a "Master", all inverters are in free mode in the system.
Master mode	When one inverter is set as a "Master", this inverter enters master mode. Master mode can be changed to free mode.
Slave mode	Once one inverter is set as a "Master", all other inverters will enter slave mode automatically. slave mode can not be changed from other modes by LCD setting.

#### "Master Inverter" setting in LCD display

Find the inverter connected with the SoloX meter, then enter the setting page of the inverter LCD screen, click on the parallel settings, and select "master control"; then enter the "resistance switch" and set it to "ON"; Finally, find the last slave in the parallel system and enter the setting page of the inverter LCD screen and set the "resistance switch" to "ON".

- If one inverter want to exit from this parallel system, please do the steps as below:  
step 1: Disconnect all the network cables on the CAN port.  
step 2: Disconnect all power cables (R/S/T/N/PE) connected to X3-Parallel Box.  
step 3: Enter setting page and click parallel setting, and choose "Free".

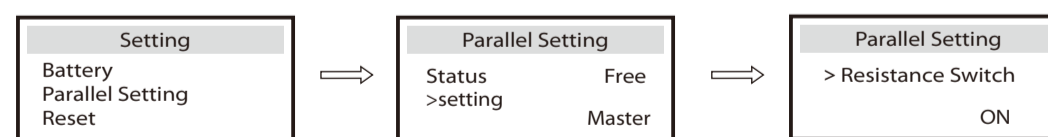

Notes: Once this inverter is set as a "Master" all other inverters will enter "slave mode" automatically.

#### Main display:

Once inverter enters parallel system, the "today yield" will be replaced by " Inverter Class", and parallel relevant fault has a higher priority than other faults and will be showed firstly on main display.

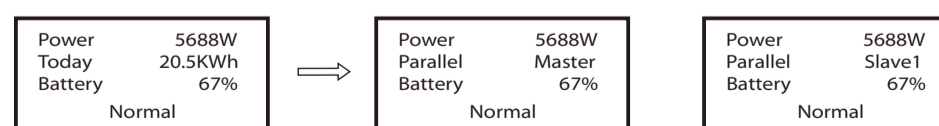

#### Status display:

User can obtain all the status data from master inverter. System power and individual slave inverter power can be obtain in status display of master inverter.

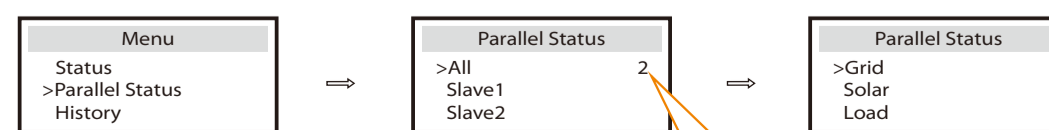

Means the total number of online inverters.